



Aussie Locker®

INSTALLATION MANUAL

Aussie Locker Standard Installation Instructions By:

Made in USA By:

TORQ-MASTERS
INDUSTRIES

Aussie Locker®

INSTALLATION MANUAL

Aussie Locker Standard Installation Instructions By:



INTRODUCTION

We suggest that you read these instructions before beginning your installation to familiarize yourself with the installation steps. Review your Aussie Locker kit parts and confirm you ordered the correct part number before you start the installation.

Installation of your new locker is accomplished by removing the differential gears from the differential case and installing the Aussie Locker™ components in their place. This type of installation can be made by the weekend mechanic who is familiar with the operation of a differential and who is able to exercise appropriate care during the installation process. Normal installation takes about two hours when these instructions are followed. They also assume that the installer has a shop manual covering the vehicle and that they are familiar with the procedures used in removing wheels, axle shafts, etc. Shortcuts should not be attempted unless the installer is very familiar with the shop manual procedures for the vehicle.

Great care has been taken in developing these instructions for the proper installation of the Aussie Locker™; however, the final results are the responsibility of the installer. After the locker is installed, the safe operation of the vehicle is the responsibility of the driver. Anyone who drives the vehicle should read the Operator's Guide for additional information on how to safely operate your new locker- equipped vehicle.

NOTE: Aussie Locker™ is for Open Differentials Only

AUSSIE LOCKER™ PARTS LIST

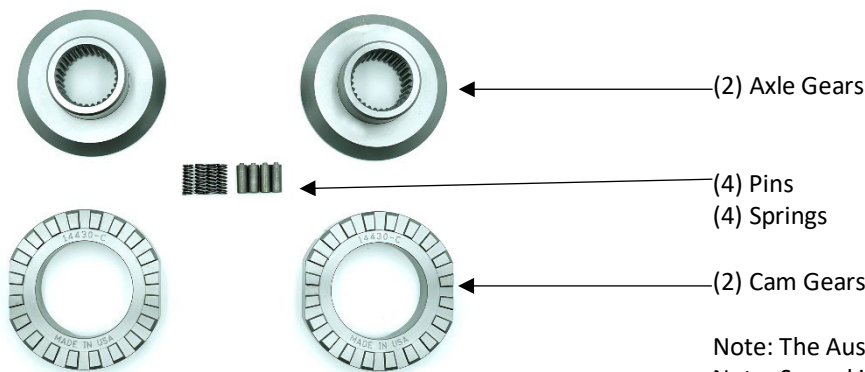

Note: The Aussie Locker™ does not have spacer cups
Note: Some kits include additional parts and instructions

ADDITIONAL PARTS & RECOMMENDED TOOLS

Only reuse the stock components if they are in excellent condition. We recommend replacing the stock spider if your differential has over 150,000 miles or if the surfaces of the individual shafts are scored. Visit www.TorqMasters.com for replacement stock components and custom thickness thrust washers if needed.

For your installation, you will need:

- **Stock or aftermarket side gear Thrust Washers**
- **Stock or aftermarket Cross Pin**
- **Gear Oil** – Use OEM recommended oils, or to reduce locker audible ‘click’ use Conventional 85W-140
- **Gasket maker material.**
- **Shop manual for vehicle** – Haynes or Chilton Manuals are sufficient.
- **Dial caliper or feeler gauge** – for measuring center gap.
- **Paint pen or Sharpie Marker**

TYPES OF AXLE ASSEMBLIES

The Aussie Locker™ is designed to fit a number of different types of axle assemblies:

- Dana Style axle assemblies
- Third Member style axle assemblies
- C-clip style axle assemblies
- Full float axle assemblies
- Front/steering axle assemblies
- Differentials that utilize a trust block

A supplemental instruction sheet will be included in your installation manual packet if there are model specific installation notes.

INSTALLATION

- 1.) **Prep vehicle for install & remove Spider Gears:** Engage the parking brake. Lift the vehicle and place jack stands under your axles. Put the transfer case in NEUTRAL to free up the drive shaft so that the differential case can be rotated if necessary. Remove the differential cover and drain the oil, or loosen the 3rd member bolts and drain the oil. Pull both axle shafts out about 4", be mindful of your axle seals, consult your Shop Manual for vehicle specific instructions. If you have a 3rd member style axle assembly, remove the 3rd member and work on the differential on the workbench. Remove the cross pin, spider gears and all thrust washers. For higher gear ratios, you will need to pull the differential case out of the axle housing, then remove the ring gear to gain access to remove the cross pin and spider gears, again, consult your shop manual.

Tip: If you need to remove your differential case to remove the ring gear, use a paint pen to make index marks on your bearing cap retainers, and on the ring gear to differential case. Upon reassembly align all index marks. No need to setup the Ring and Pinion backlash and preload.

- 2.) **Examination of the parts:**
 - a. Inspect the two large side gear thrust washers for wear, cracks, warping or galling. If they are not in excellent condition replace them. The side gear thrust washers will be reused in the Aussie Locker install. The cupped small washers under the side spider gears will not be reused.
 - b. Examine the cross pin. If it worn by more than .002 where the side gears were located, purchase a new one.
 - c. Check the hardness of the cross pin. Slide a file across the middle of the cross pin. If the file cuts into the pin, replace it. If the file does not cut the pin it should be suitable to re-use in the Aussie Locker install.
 - d. Check the cross pin hole in the differential case, if the cross pin hole is wallowed out and cross pin has play in the case, the case will need to be replaced and is not suitable for an Aussie Locker installation.
 - e. Thoroughly clean the differential housing to remove any old dirt, gasket and metal particles.
 - f. Examine the differential case and bearings. If there are any chips or cracks in the case and/or the bearings, or if the bearings are worn, replace them.

- 3.) **Prep Aussie Locker for Install:** Ensure your work area is clean and that no dirt or metal particles are present. Apply medium grease, in a very thin coating, to the teeth of the gears and to the backs of the axle gears

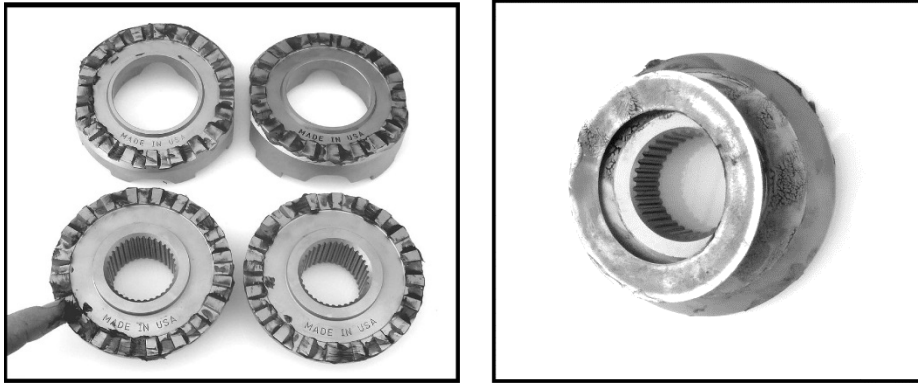

- 4.) **Thrust Washers:** Install new or existing thrust washers onto the backs of the axle gears and press them into the grease to help hold them in place.



- 5.) **Install Axle 2 Gears:** with Thrust Washers on the backs of the axle gears, driver and passenger side
- 6.) **Install First Cam Gear:** on Ring Gear side of the case, push it into the grease on the teeth to hold it in position.
- 7.) **Install Second Cam Gear:** Push the right cam gear into the grease to hold it in position.



- 8.) **Install the Pins and Springs:** Pins go in the hole, springs go in the slot. The nub on pin retains bottom loop of spring. It's helpful if you use the nub on the pin to hold the spring in place, then use a small screw driver to compress the spring and pop it into the slot. It's critical to install the pins and springs in the correct orientation. Failure to install in the correct orientation could lead to severe damage in the differential.



- 9.) **Reinstall the Cross Pin and Roll Pin** rotate the cam gears as necessary to align the cross pin recess. Install the cross pin
- 10.) **Check the Center Gap Measurement:** Use your caliper or feeler gauges to measure the gap between the two cam gears with the locker teeth engaged. This is an installation check to see if the thrust washers were installed or to see if the differential case is within average machining tolerances or if it has become worn. If the gap is out of specifications, please contact Customer Support: Info@TorqMasters.com

NOTE: Center Gap Spacing = Between 0.145" and 0.170"

- 11.) **Perform the 'Spin Test':** Perform the Wheel Spin Test
- Jack the front or rear of the vehicle up and place on jack stands so tires are off the ground. Ensure the vehicle is stable.
 - Place the vehicle in gear, in 4wd to lock the pinion.
 - Tires must be installed to complete this test.
 - Rotate the Drivers side tire forward until it stops against the locked drive shaft. Hold it in position and maintain moderate pressure.
 - While holding the Drivers side tire, rotate the Passenger side tire backwards. It should ratchet smoothly, with the locker clicking as the tire rotates.
 - Next rotate the Drivers side tire backwards until it stops against the locked drive shaft. Hold it in position and maintain moderate pressure.
 - Then, rotate the Passenger side tire forwards. It should ratchet smoothly, with the locker clicking as the tire rotates.
 - Repeat steps 4-7 this time starting with the Passenger side tire
 - If your locker ratchets smoothly, then you have passed the "wheel spin" test and you are ready to finish up.
 - Any questions? Shoot us an email or give us a call. Info@torqmasters.com
- Note: The "click" will be less noticeable when the cover is installed and the housing is filled with oil.
- 12.) **Complete Installation:** Remove any remaining gasket on the gasket surface on the axle housing and diff cover/3rd member and clean with brake cleaner. Reinstall the differential cover or 3rd member and add gear oil. Fill with your OEM recommended oil, or for less 'Click' noise use Conventional 85W-140. Leave the vehicle in gear, apply the emergency brake, remove the jack stands and lower the vehicle to the ground.

TEST DRIVE

- After your installation is complete and you have passed the 'Spin Test' it's time to take your vehicle out for a test drive. Consult the Operator's Guide for detailed information on how to operate your vehicle on and off road.
- During your initial testing, take it easy the first few miles. Remember that a new rear locker-equipped vehicle will have some different handling characteristics that you will quickly adapt to. Take turns slowly and coast through the turn in rear-locker applications. Front locker applications should see no change in handling characteristics while in 2WD. It is not recommended to test a front locker in 4WD on dry pavement.
- Try your locker on a low-traction surface like a gravel parking lot to feel how the added traction feels.
- Note, there is a break-in period for your locker of about 600 miles after which the 'Click' noise should reduce slightly. The occasional 'Clunk' may be heard with this style of locker and should not be cause for concern.

NOTES & HELPFUL HINTS

- **Axle Seals:** Inspect while you are in the differential, now would be a good time to replace if needed
- **Differential case and bearings:** If there are any chips or cracks in the case, and/or the bearings are worn, replace them—but remember that the ring and pinion backlash and bearing pre-load will need to be set up again after replacing.
- **Thick Ring Gear:** If the Ring Gear is thick and interferes with the removal of the Cross Pin; pull the two axle shafts, pull the differential case from the axle housing, pull the ring gear from the case, then remove the Cross Pin and differential gears. Refer to your vehicle shop manual for this procedure as this varies between axle assemblies. A case spreader or high-lift jack may be necessary for some applications.

WARRANTY

AUSSIE Locker™ TWO YEAR LIMITED WARRANTY

Torq-Masters Industries warrants each new AUSSIE Locker™ to be free from defects in material and workmanship under normal use and service following the date of purchase of the part for a period of four years. This warranty is limited to the manufacturer's repair or replacement of the defective parts only, providing the product, including all components and parts, is returned to the manufacturer or its authorized representative, together with proof of purchase and all relevant documentation, transportation charges prepaid. This warranty excludes labor or consequential damages or injury. The decision as to whether the defective part is to be repaired or replaced will rest solely with Torq-Masters Industries, Inc. The Aussie Locker pins and springs are not covered under warranty and are considered a wear item. Any failure of the product as before described must be reported to the manufacturer within fifteen (15) days of failure and an authorization code number obtained for return of the product to manufacturer or its authorized representative. Proper proof of purchase must be furnished in order to obtain an authorization code; and this code number must be included with the relevant paperwork before mentioned. Please contact us to obtain a return authorization code.

Notes:

This warranty is in lieu of all other warranties express or implied and all other obligations or liabilities on the part of the manufacturer. The manufacturer neither assumes nor authorizes any other entity or person to assume for it any other liability in connection and sale of AUSSIE Lockers™

This warranty covers the original purchaser only. This warranty does not cover defects caused by any of the following: modification, alteration, repair or service of the product by anyone other than by the manufacturer or its authorized representative, physical abuse to or misuse of the product, improper diagnosis, installation or operation thereof in a manner contrary to the installation manual accompanying the product, and road, offroad or accident damage. No repair or replacement of any part made under this warranty shall be deemed to alter or extend the term of the warranty in any way.

The manufacturer disclaims any implied warranties of merchantability of the goods or fitness of the goods for any purpose. The manufacturer has no liability for incidental, consequential or special damages including, but not limited to, claims of personal injury or property damage and claims of liabilities by third parties not the original purchaser to the product. While this warranty gives specific legal rights, some States have special laws regarding warranties which regulate limitation and time periods. These rights vary from state to state and purchaser is urged to review laws of his jurisdiction in the event of a warranty question.

If the purchaser disagrees with any of the terms of this warranty, please return the purchased item to Torq-Masters Industries, Inc. within three (5) business days of notification of shipment. Buyer is responsible for all shipping charges for receipt and return of product. A decision by the purchaser to retain the item purchased will be deemed acceptance of the specific terms of this warranty.

RECORD AND SAVE THIS INFORMATION. FAILURE TO DO SO MAY VOID WARRANTY

Purchase Date: _____

Order Number: _____

Model Number: _____

Vehicle Make & Model: _____

Center Gap Measurement: _____

Did the Locker Pass the Spin Test? _____

Aussie Locker™ is 100% made in the USA.

Please direct any questions to: info@torqmasters.com

January 1st, 2017 Copyright by Torq-Masters Industries Inc.
Aussie Locker is a trademark of Torq-Masters Industries Inc.